



Electrolux
PROFESSIONAL

Modular Cooking Range Line thermaline 80 - Electric Free- cooking Top on Oven H=800

ITEM # _____

MODEL # _____

NAME # _____

SIS # _____

AIA # _____



588425 (MATGFAH8AO)

Electric Free-Cooking Top,
one-side operated, on Oven

Short Form Specification

Item No.

Unit constructed according to DIN 18860_2 with 20 mm drop nose top. Internal frame for heavy duty sturdiness in stainless steel. 2 mm top in 1.4301 (AISI 304). Flat surface construction, easily cleanable. THERMODUL connection system enables seamless worktop when units are connected and avoids soil penetrating. Smooth electrically-heated solid plate made of 20 mm thick steel with a wide rounded cleaning zone around the plate. Rapid plate heat up, continuously ready to use; maximum reachable surface temperature of 350°C. Overheat protection switches off the supply in case of overheating. Standby function saves energy and quickly recovers maximum power. Metal knobs with embedded hygienic silicon "soft" grip enable easier handling and cleaning.

Electric static oven base with 40 mm thick oven door and ribbed enamelled steel base plate. Constructed according to 1.4301 (AISI 304). Oven chamber with 2 levels of runners for 2/1 GN shelves to enable simultaneous and faster cooking. Heavy duty thermostat with temperature range up to 300°C, electronic sensor for precise temperature control and manual humidity control in the cooking chamber. Upper heating element can also be used for grilling, with or without ventilating mode. Flat surface construction, easily cleanable. Overheat protection switches off the supply in case of overheating. Standby function saves energy and quickly recovers maximum power. Metal knobs and oven handles ergonomically designed with embedded hygienic silicon "soft" grip enable easier handling and cleaning. IPX5 water resistance certification.

Main Features

- Rapid heat up of the plate and continuously ready for use.
- Overheat protection: the temperature sensor switches off the supply in case of overheating.
- Stainless steel high splash guards on the rear and sides of cooking surface.
- Wide rounded cleaning zone around the plates for easier cleaning.
- 40 mm thick oven door for heat insulation.
- All major components may be easily accessed from the front.
- THERMODUL connection system creates a seamless work top when units are connected to each other thus avoiding soil penetrating vital components and facilitating the removal of units in case of replacement or service.
- Metal knobs with embedded hygienic "soft-touch" grip for easier handling and cleaning. The special design of the controls prevents infiltration of liquids or soil into vital components.
- Large visible digital display manufactured in tempered glass to resist heat and chemicals, showing temperatures or power settings. The display also shows on/off status of the appliance and on/off status of the heating elements.
- Cooking plate and base joint profile guarantee against soil infiltration.
- Surface temperature up to 350°C
- Handles are ergonomically designed with silicon "soft" grip for easy handling and cleaning.
- Oven chamber to have 2 levels of runners to accommodate 2/1 GN trays and ribbed enamelled steel base plate.
- Heavy duty thermostat with temperature range up to 300°C.
- The upper heating element of the oven can also be used for grilling.
- Manual control of humidity in cooking chamber.
- Electronic sensor for precise temperature control.
- Unit constructed according to DIN 18860_2 with 70 mm recessed plinth.
- For direct and indirect cooking.
- Oven temperature up to 300 °C

Construction

- Unit constructed according to DIN 18860_2 with 20 mm drop nose top and 70 mm recessed plinth.
- Flat surface construction with minimal hidden

APPROVAL: _____



Experience the Excellence
www.electroluxprofessional.com

areas to easily clean all surfaces

- Unit constructed according to DIN 18860_2 with 20 mm drop nose top.
- IPX5 water resistance certification.
- Cooking surface is an electrically heated solid plate made from 20 mm thick stainless steel AISI 316 - DIN 1.4404.
- 2mm thick top in stainless steel AISI 304 - DIN 1.4301.
- Internal frame for heavy duty sturdiness in stainless steel.

Sustainability



- Standby function for energy saving and fast recovery of maximum power.

Included Accessories

- 1 of Grid, chromium plated, for ovens PNC 910652
2/1 GN

Optional Accessories

- | | | |
|--|------------|--------------------------|
| • Baking sheet 2/1 GN for ovens | PNC 910651 | <input type="checkbox"/> |
| • Bottom steel plate 2/1 GN for fire clay plate 800&900 with baking oven | PNC 910655 | <input type="checkbox"/> |
| • Fire clay plate 2/1 GN for ovens | PNC 910656 | <input type="checkbox"/> |
| • Connecting rail kit, 800mm | PNC 912500 | <input type="checkbox"/> |
| • Stainless steel side panel, 800x800mm, freestanding | PNC 912508 | <input type="checkbox"/> |
| • Portioning shelf, 1000mm width | PNC 912528 | <input type="checkbox"/> |
| • Portioning shelf, 1000mm width | PNC 912558 | <input type="checkbox"/> |
| • Folding shelf, 300x800mm | PNC 912577 | <input type="checkbox"/> |
| • Folding shelf, 400x800mm | PNC 912578 | <input type="checkbox"/> |
| • Fixed side shelf, 200x800mm | PNC 912583 | <input type="checkbox"/> |
| • Fixed side shelf, 300x800mm | PNC 912584 | <input type="checkbox"/> |
| • Fixed side shelf, 400x800mm | PNC 912585 | <input type="checkbox"/> |
| • Stainless steel front kicking strip, 800mm width | PNC 912598 | <input type="checkbox"/> |
| • Stainless steel side kicking strips left and right, freestanding, 800mm width | PNC 912619 | <input type="checkbox"/> |
| • Stainless steel side kicking strips left and right, back-to-back, 1610mm width | PNC 912625 | <input type="checkbox"/> |
| • Stainless steel plinth, freestanding, 800mm width | PNC 912825 | <input type="checkbox"/> |
| • Connecting rail kit: modular 80 (on the left) to ProThermetic tilting (on the right), ProThermetic stationary (on the left) to ProThermetic (on the right) | PNC 912971 | <input type="checkbox"/> |
| • Connecting rail kit: modular 80 (on the right) to ProThermetic tilting (on the left), ProThermetic stationary (on the right) to ProThermetic (on the left) | PNC 912972 | <input type="checkbox"/> |
| • Endrail kit, flush-fitting, left | PNC 913109 | <input type="checkbox"/> |
| • Endrail kit, flush-fitting, right | PNC 913110 | <input type="checkbox"/> |
| • Scraper for smooth plates | PNC 913119 | <input type="checkbox"/> |
| • Endrail kit (12.5mm) for thermaline 80 units, left | PNC 913200 | <input type="checkbox"/> |
| • Endrail kit (12.5mm) for thermaline 80 units, right | PNC 913201 | <input type="checkbox"/> |

- Stainless steel side panel, left, h=800 PNC 913216
- Stainless steel side panel, right, h=800 PNC 913217
- T-connection rail for back-to-back installations without backsplash (to be ordered as S-code) PNC 913227
- Insert profile D=800mm PNC 913230
- Energy optimizer kit 32A - factory fitted PNC 913247
- Endrail kit, (12.5mm), for back-to-back installation, left PNC 913249
- Endrail kit, (12.5mm), for back-to-back installation, right PNC 913250
- Endrail kit, flush-fitting, for back-to-back installation, left PNC 913253
- Endrail kit, flush-fitting, for back-to-back installation, right PNC 913254
- Side reinforced panel only in combination with side shelf, for freestanding units PNC 913257
- Side reinforced panel only in combination with side shelf, for back-to-back installations, left PNC 913273
- Side reinforced panel only in combination with side shelf, for back-to-back installation, right PNC 913274
- Filter W=800mm PNC 913665
- Stainless steel dividing panel, 800x800mm, (it should only be used between Electrolux Professional thermaline Modular 80 and thermaline C80) PNC 913669
- Electric mainswitch 63A 10mm² NM for modular H800 electric units (factory fitted) PNC 913677
- Stainless steel side panel, 800x800mm, flush-fitting (it should only be used against the wall, against a niche and in between Electrolux Professional thermaline and ProThermetic appliances and external appliances - provided that these have at least the same dimensions) PNC 913685

Recommended Detergents

- C41 HI-TEMP RAPID DEGREASER, 1 pack of six 1 lt. bottles (trigger incl.) PNC 0S2292



Front

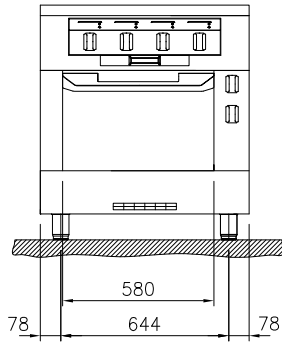

Side

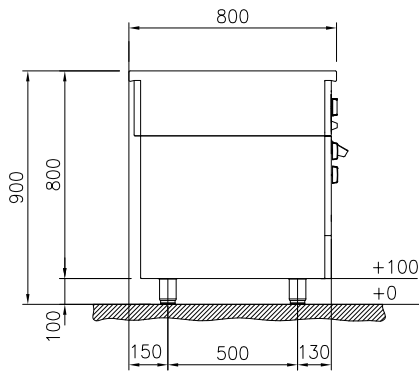

EI = Electrical inlet (power)
EQ = Equipotential screw

Top

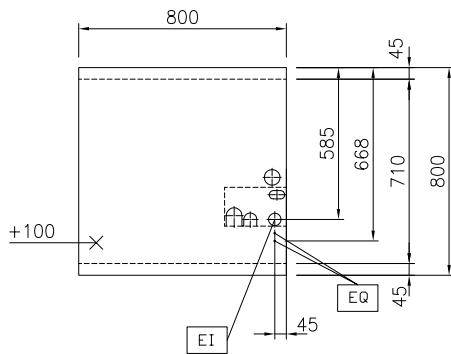

Electric

Supply voltage: 400 V/3N ph/50/60 Hz
Electrical power, max: 17.3 kW

Key Information:

Working Temperature MIN: 80 °C
Working Temperature
MAX: 350 °C
External dimensions,
Width: 800 mm
External dimensions,
Depth: 800 mm
External dimensions,
Height: 800 mm
Storage Cavity Dimensions
(width):
Storage Cavity Dimensions
(height):
Storage Cavity Dimensions
(depth): 0 mm
Net weight: 208 kg
Configuration: On Oven; One-Side
Operated
Front Plates Power: 3 - 3 kW
Back Plates Power: 3 - 3 kW
Solid top usable surface
(width): 670 mm
Solid top usable surface
(depth): 650 mm

Sustainability

Current consumption: 31.7 Amps